

3" HEAVY DUTY TRIDICATORS

Dual reading pressure and temperature instrument

High quality, economical design for use in commercial and industrial boiler applications

SPECIFICATIONS

Dial	3" (76.2 mm)
Case	Heavy duty, dry non-fillable
Stem	2", copper alloy
Lens	Glass
Pointer	Black aluminum
Connection	Lower mount Center back mount
	1/2" NPT, copper alloy
Scale	Pressure: dual scale psi & feet of water Temperature: dual scale °F & °C
Temperature Range	70/320° F & 20/160° C
Accuracy	3-2-3% full scale per Grade B, ASME B40.1
Ambient Temp*	-30° F to 180° F

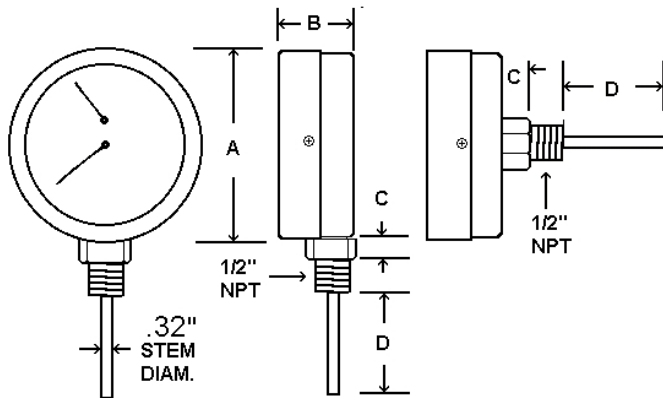

Dial	Unit	A	B	C	D
3"	In.	3.21"	1.29"	0.32"	2.00"
	mm	81.5	33	8	51

AVAILABLE OPTIONS*

- Custom Dial
- Special Connection Size
- Single Scale
- Special Ranges
- Custom Lens Material
- 316 Stainless Steel Wetted Parts

*Lead times/minimums may apply

APPROXIMATE SHIPPING WEIGHTS/BOX QUANTITIES

Dial Size	Est. Unit Weight	Box Qty
3"	0.70 lbs (0.32 kg)	50

PART NUMBER	CONNECTION	DIAL SIZE	PRESSURE		TEMPERATURE	
			psi	Ft of Water	F	C
TRI-HD-302L-E	Lower	3"	0/100	0/230	70-320°	20-160°
TRI-HD-302L-G	Lower	3"	0/200	0/450	70-320°	20-160°
TRI-HD-302R-E	Center Back	3"	0/100	0/230	70-320°	20-160°
TRI-HD-302R-G	Center Back	3"	0/200	0/450	70-320°	20-160°

*NOTE: High or low ambient temperatures may have adverse effect on accuracy. Consult PIC Gauges for instrument selection.